



INSTRUCTION MANUAL

245 MHz FM TRANSCEIVER

**IC-3FX**

---

---

---

Icom Inc.

---

---

## IMPORTANT

---

**READ ALL INSTRUCTIONS** carefully and completely before using the transceiver.

**SAVE THIS INSTRUCTION MANUAL.** This manual contains important safety and operating instructions for the **IC-3FX**.

---

## CAUTIONS

---

**NEVER** allow the antenna to come close to, or touch, exposed body parts, especially the face or eyes while transmitting.

**NEVER** disassemble the transceiver. Incorrect reassembly may result in a fire hazard or electric shock.

**NEVER** operate the transceiver near unshielded electrical blasting caps or in an explosive area.

**AVOID** the use of chemical agents such as benzene or alcohol when cleaning—use a water-dampened cloth only.

---

## TABLE OF CONTENTS

---

IMPORTANT .....	i
CAUTIONS .....	i
TABLE OF CONTENTS .....	i
<b>1 GETTING STARTED .....</b>	<b>1</b>
<b>2 PANEL DESCRIPTION .....</b>	<b>2</b>
<b>3 BASIC OPERATION.....</b>	<b>3-4</b>
<b>4 DEALER-PROGRAMMABLE FUNCTIONS .....</b>	<b>5-7</b>
■ General.....	5
■ Functions.....	5
<b>5 BATTERY PACKS .....</b>	<b>8-11</b>
■ Battery pack replacement.....	8
■ Cautions .....	8
■ Charging.....	9
<b>6 CHANNEL LIST .....</b>	<b>12</b>
<b>7 SPECIFICATIONS .....</b>	<b>13</b>
■ Specifications .....	13
■ Options .....	13

## ◇ UNPACKING

The transceiver comes supplied with the following accessories\*.

- ① Flexible antenna
- ② Belt clip
- ③ 1922A REAR-SHEET

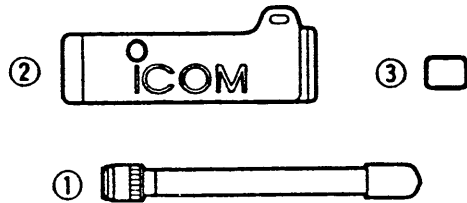

## ◇ ANTENNA

The antenna screws onto the transceiver as illustrated below.

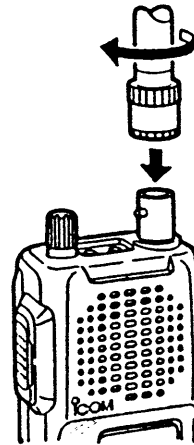

## ◇ TURNING POWER ON

Rotate the volume control to the 12 o'clock position.

- A power-up alert tone sounds for about 2 sec. and an opening message may appear.

(Above functions depend on pre-setting.)  
Then a channel number appears on the display.

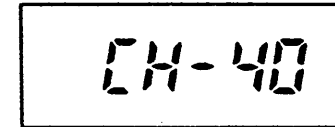

Channel number may differ from this.

## ◇ BELT CLIP

Attach the belt clip to the transceiver as illustrated below.

Attach the belt-clip

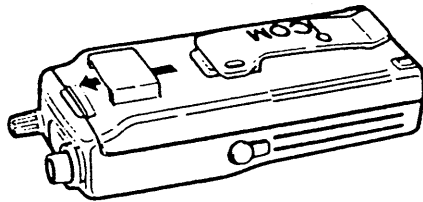

Release the belt-clip

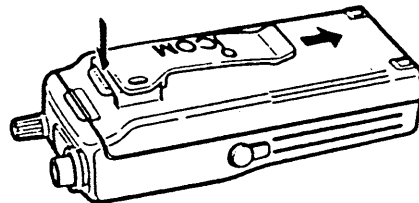

**NOTE:** If the power-up alert tone does not sound or a channel number does not appear on the display, turn the transceiver OFF, check the battery, then turn the transceiver back ON.

If the power-up tone still does not sound or a channel number does not appear, charge the battery or replace it.

**NOTE:** To increment or decrement the displayed channel, push the [▲] or [▼] keys.

# PANEL DESCRIPTION

## VOLUME CONTROL [OFF/VOL]

Turns power ON and adjusts the audio level.

## PTT SWITCH [PTT]

Push and hold to transmit; release to receive.

## UP/DOWN KEYS [▲]/[▼]

Push to select the operating channel.

## DEALER-PROGRAMMABLE SWITCH/KEYS

[P0]/[P1]/[P2]/[P3]/[A]/[B]/[C]/[D]  
[◀]/[▶]

Can each be programmed for one of several functions by your Icom Dealer.

## KEYPAD

Used to enter operating channel, etc.

## ANTENNA AND CONNECTOR

Connects the supplied antenna.

## [SP]/[MIC] JACK

Connect optional speaker-microphone.

## FUNCTION DISPLAY

Displays the following information:

- CH number.
- Keypad lock indication.
- 5-Tone indication.
- Audible indication.
- Low-battery indication.
- Skip-ch indication.
- Low-power indication.
- Busy indication.
  
- 5-tone code number.
- RF indicator
  - 2 segments at low power and all segments at high power.

 **NOTE:** Above functions depend on presetting.

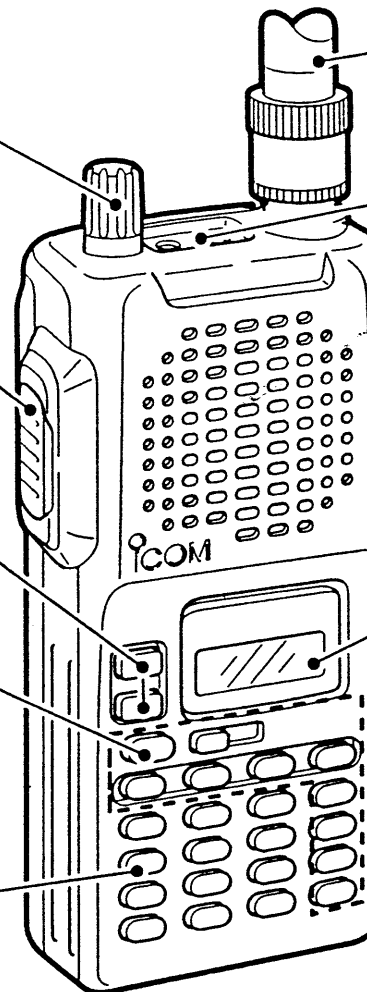

## ■ Receiving and transmitting

/// **NOTE:** Transmitting without an antenna may damage the transceiver. See p.1 for antenna attachment.

Turn power ON as described on p.1.

*Receiving:*

- ① Push [▲]/[▼] to select a channel.
- ② Listen for a transmission and adjust [VOL] to a comfortable listening level.
  - When no transmission is heard, push and hold [MONI] while adjusting [VOL] (your transceiver may not be programmed with the monitor function).

The transceiver is now set to receive desired calls on the selected channel.

*Transmitting:*



Wait for the channel to become clear to avoid interference.

- ③ While pushing and holding [PTT], speak into the microphone at a normal voice level.
  - When a tone signalling system is used, the call procedure described at right may be necessary.
- ④ Release [PTT] to return to receive.

/// **IMPORTANT:** To maximize the readability of your transmitted signal, pause a few secs. after pushing [PTT], hold the microphone 10 to 15 cm from your mouth and speak at a normal voice level.

## ■ Transmitting notes

### ◇ LOW BATTERY INDICATION

- When  appears, battery capacity is becoming low and transmitting is impossible.
- When  flashes, battery capacity is nearly exhausted.

### ◇ TIME-OUT TIMER

After continuous transmission for a pre-programmed period, the time-out timer is activated, causing the transceiver to stop transmitting and automatically select receive.

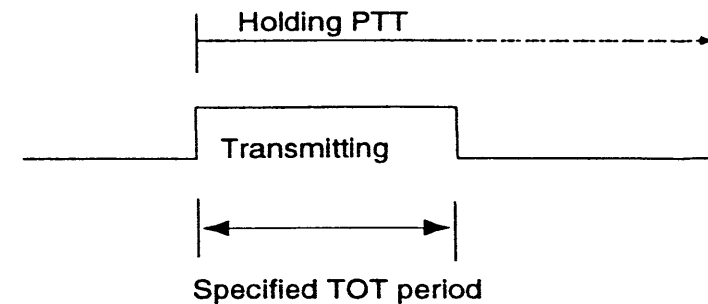

### ◇ PENALTY TIMER

Once the time-out timer is activated, transmission is further inhibited for a period determined by the penalty timer.

## ■ General

Consult your Icom Dealer or System Operator for details concerning your transceiver's programming. When available, programmed functions are assigned to [P0], [P1], [P2], [P3], [A], [B], [C], [D] [◀] and [◀].

In the following explanations, programmable function names are bracketed, the specific switch used to activate the function depends on programming.

## ■ Functions

### ◆ KEYPAD LOCK FUNCTION

This function locks access to all programmable switches (except the switch assigned the lock function).

*To toggle the lock function ON and OFF:*

Push and hold [LOCK] for 1 sec.

- "  " appears while the lock function is ON.
- This function may be inhibited on some channels.

### ◆ PRIORITY CHANNEL

This function is used to select a pre-programmed channel at the push of a switch.

*To select the priority channel:*

Push [PRIORITY].

- "PRIO" appears briefly, then the priority channel is automatically selected.

### ◆ SCAN FUNCTION

The scan function allows you to search a pre-programmed group of channels for signals.

*To start/stop scan:*

Push [SCAN].

- Scan pauses on a channel when receiving a signal.
- Depending on programming, a message may appear while scanning.
- "Lockout SCAN" (pre-programmed list SCAN) or "Priority SCAN" can be pre-programmed.
- When the "Power-save function" is activated, the transceiver checks all pre-programmed channels then returns to the "Power-save function" again.

### ◆ BEEP FUNCTION

This function provides confirmation beep tones when pushing switches.

*To toggle the function ON and OFF:*

Push [BEEP].

## 4 DEALER-PROGRAMMABLE FUNCTIONS

### ◆ MONITOR FUNCTION

The monitor function allows you to open the transceiver's squelch manually to check whether a channel is busy or not. The transceiver has 2 conditions for receive standby:

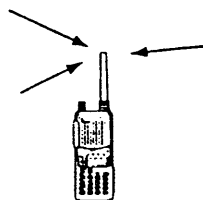

all signals are received

#### Audible condition:

This condition mutes audio ONLY when no carrier is present. You can receive (or monitor) any signals on a channel.

- Push and hold [MONI/AUDI] to select the audible condition.
- Any audio mute functions are cancelled while pushing [MONI/AUDI].

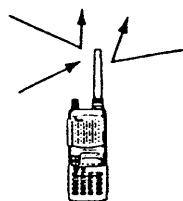

only signals containing the proper tone are received

#### Inaudible condition:

This condition mutes ALL signals except those directed to you. Therefore you should check a channel's condition (busy or not) with the monitor function before transmitting.

- Push [MONI/AUDI] momentarily to select the inaudible condition.

### ◆ HIGH/LOW POWER OUTPUT

This function selects high or low power for a channel.

*To toggle between high and low power:*

Push [HIGH/LOW].

- "LOW" appears when low output power is selected.

### ◆ DISPLAY LIGHTING

The function display has 3 backlight conditions.

- OFF** : No backlight is available
- AUTO** : When any key is pushed, the backlight turns ON for 5 sec. automatically.
- CONTINUOUS:** Backlight turns ON continuously after power ON.

### ◆ KEY ASSIGNMENT

Consult your Icom Dealer or System Operator and write down the functions for the programmable switches for your reference.

[ P0 ]		[ A ]	
[ P1 ]		[ B ]	
[ P2 ]		[ C ]	
[ P3 ]		[ D ]	
[ ◀ ]		[ ◀ ]	

## ■ Battery pack replacement

Before replacing the battery pack, the volume control **MUST** be rotated fully counterclockwise, until a click is heard, to turn the power OFF.

• *TO REMOVE* the battery pack from the transceiver:  
Push and hold the battery release downwards, then pull the battery pack upwards with the transceiver facing you.

• *TO ATTACH* the battery pack to the transceiver:  
Mate the notched ends of the battery pack and the transceiver, and push the battery pack until it clicks into place.

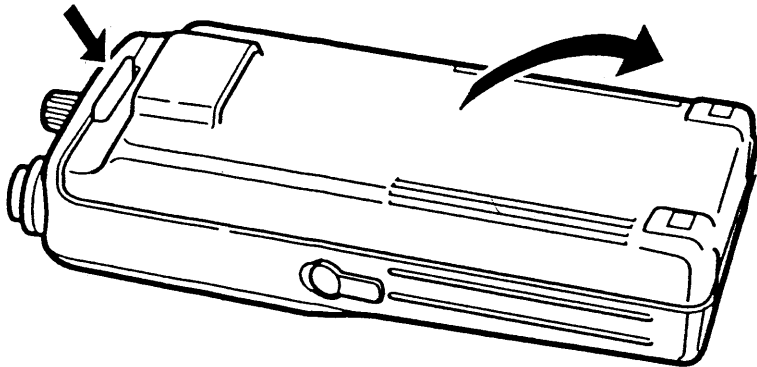

## ■ Battery cautions

**NEVER** incinerate used battery packs. Internal battery gas may cause an explosion.

**NEVER** immerse the battery pack in water. If the battery pack becomes wet, be sure to wipe it dry **BEFORE** attaching it to the transceiver.

**NEVER** short terminals of the battery pack. Also, current may flow into nearby metal objects so be careful when placing battery packs in handbags, etc.

If your battery pack seems to have no capacity even after being charged, completely discharge it by leaving the power ON overnight. Then, fully charge the battery pack again. If the battery pack still does not retain a charge (or very little), a new battery pack must be purchased.



## ■ Battery charging

Prior to using the transceiver for the first time, the battery pack must be fully charged for optimum life and operation.

**CAUTION:** To avoid damage to the transceiver, turn it OFF while charging.

- Recommended temperature range for charging: +10°C to +40°C (50°F to 104°F)
- Use the supplied charger or optional charger (BC-119/BC-121 for rapid charging) only. **NEVER** use other manufacturers' chargers.
- An optional cable OPC-254L (for 13.8 V power source) or CP-12L (for 12 V cigarette lighter socket) can be used instead of the AC adapters supplied with the above chargers.

When using the BC-119: If the charge indicator flashes orange, the vehicle battery voltage is low and charging may not be performed. Check the vehicle battery voltage in this case. If the charge indicator flashes red, there may be a problem with the battery pack (or charger). Re-insert the battery pack or contact your dealer.

## ◆ Rapid charging with The BC-119

The optional BC-119 provides rapid charging of optional Ni-Cd battery packs.

The following are additionally required:

- One AD-81
- An AC adapter (may be supplied with the BC-119 depending on version).

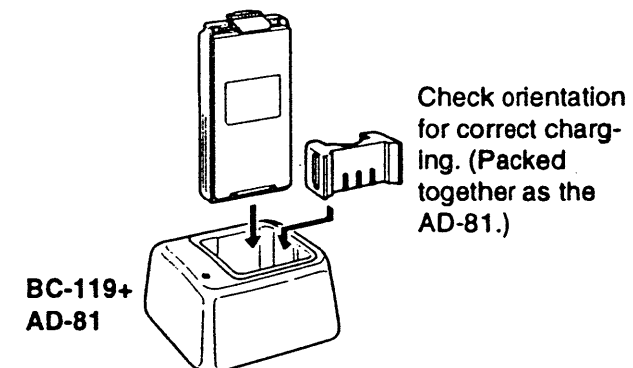
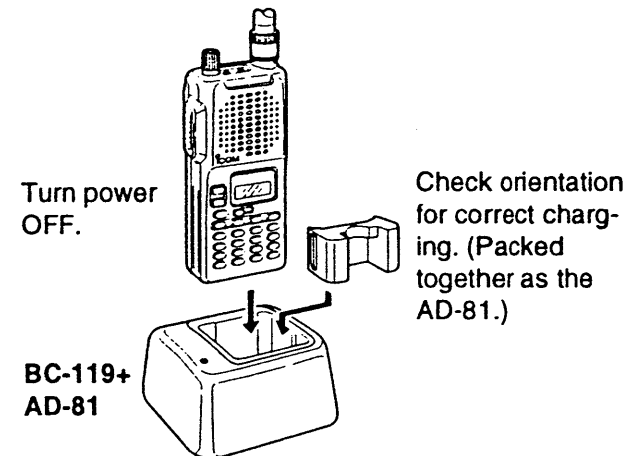

◇ Charging with optional cables

The optional CP-12L CIGARETTE LIGHTER CABLE with noise filter or OPC-254L DC POWER CABLE with a 12 to 16 V DC power source can also be used to charge the battery packs.

Connect an optional charger or cable to the transceiver as illustrated below. Be careful of battery overcharging as the connected battery is charged simultaneously.

/// **CAUTION:** Even if the power source has enough capacity, the [CHARGE] jack can be used for charging purposes only. You can not operate the transceiver without an internal power source.

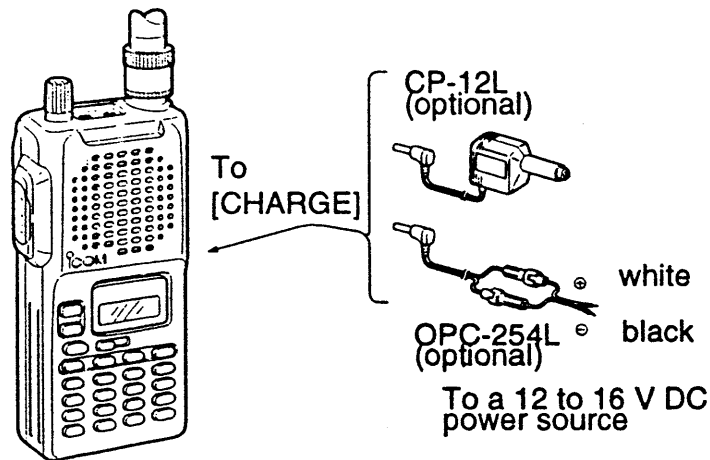

■ Optional battery pack

The optional BP-196R battery pack includes rechargeable Ni-Cd batteries and can be charged approx. 300 times. Charge the battery pack before first operating the transceiver or when the battery pack becomes exhausted.

If you want to charge the battery pack more than 300 times, the following points should be observed:

1. Avoid over charging. The charging period should be less than 48 hours.
2. Use the battery until it becomes almost completely exhausted under normal conditions. We recommend battery charging after transmitting becomes impossible.

◇ Battery pack life

When the operating period becomes extremely short even after charging the battery pack fully, a new battery pack is needed.

## 5 BATTERY PACKS

### ◇ Multiple charging with the BC-121

The optional BC-121 allows up to 6 Ni-Cd batteries to be charged simultaneously. The following are additionally required.

- Six AD-81's
- An AC adapter (may be supplied with the BC-121 depending on version).

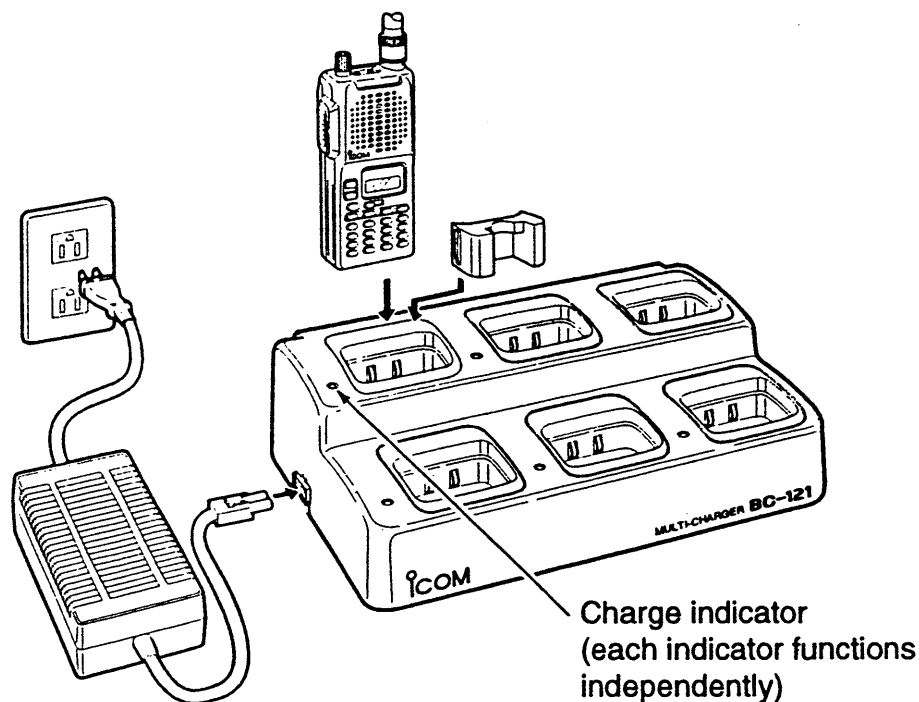

AC adapter  
(not supplied with some versions)

### ◇ Charging with the BC-110A/D/V

Connect the optional BC-110A/D/V to the [CHARGE] jack on the transceiver.

- Approx. charging period: 15 hr.
- **DO NOT** turn power ON while connecting the BC-110A/D/V. Current capacity is insufficient.

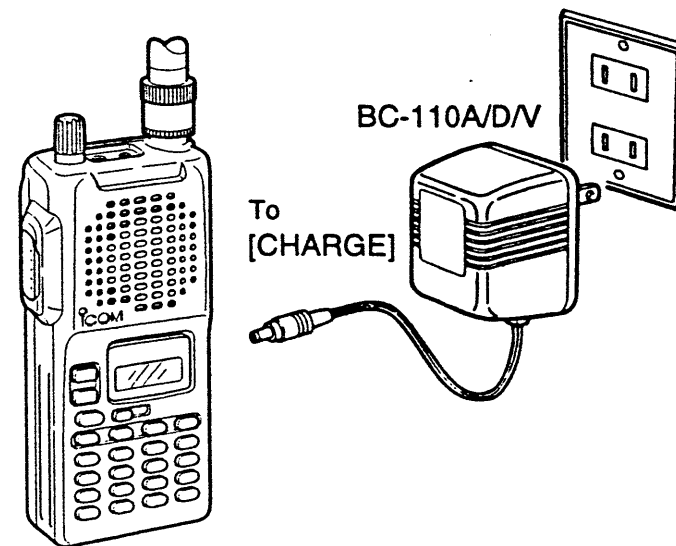

## 6

## CHANNEL LIST

## ■ Channel frequency list

CH number	Frequency*	CH number	Frequency*	CH number	Frequency*	CH number	Frequency*
CH-01	245.000	CH-11	245.250	CH-21	245.500	CH-31	245.750
CH-02	245.025	CH-12	245.275	CH-22	245.525	CH-32	245.775
CH-03	245.050	CH-13	245.300	CH-23	245.550	CH-33	245.800
CH-04	245.075	CH-14	245.325	CH-24	245.575	CH-34	245.825
CH-05	245.100	CH-15	245.350	CH-25	245.600	CH-35	245.850
CH-06	245.125	CH-16	245.375	CH-26	245.625	CH-36	245.875
CH-07	245.150	CH-17	245.400	CH-27	245.650	CH-37	245.900
CH-08	245.175	CH-18	245.425	CH-28	245.675	CH-38	245.925
CH-09	245.200	CH-19	245.450	CH-29	245.700	CH-39	245.950
CH-10	245.225	CH-20	245.475	CH-30	245.725	CH-40	245.975

\*Unit = MHz

## ■ Specifications

### • GENERAL

Frequency coverage : 245.000–245.975 MHz  
 CH step : 25 kHz  
 Mode : 16K0F3E  
 Useable temperature range : –10°C to +60°C  
 : +14°F to +140°F  
 Dimensions : 57(W)×140(H)×37(D) mm  
 (projections not included)  
 Weight (with BP-196R) : 390 g

### • TRANSMITTER

Output power : 5 W

### • RECEIVER

Sensitivity (12 dB SINAD) : 0.25  $\mu$ V Typ.  
 Intermodulation rejection ratio : More than 60 dB  
 Spurious response rejection ratio : More than 60 dB  
 Adjacent channel selectivity : More than 60 dB  
 Audio output power : 500 mW (at 5% distortion  
 with an 8 $\Omega$  load)

All stated specifications are subject to change without notice or obligation.

## ■ Options

### • HM-54/HM-46/HM-75A SPEAKER-MICROPHONES

Combination speaker-microphone that provides convenient operation while hanging the transceiver from your belt clip.

### • BC-119 DESKTOP CHARGER (or BC-121 MULTI-CHARGER) + AD-81 DESKTOP CHARGER ADAPTER

Used for rapid charging of battery packs. Charging time: 1.5 to 2 hours. An AC adapter is supplied with the chargers (depending on version). BC-121 rapidly charges up to 6 battery packs at once.

### • BC-110A/D/V WALL CHARGER

Used for charging via a domestic AC wall socket.

### • CP-12L CIGARETTE LIGHTER CABLE

Used for charging via a vehicle's cigarette lighter socket (12 V).

### • OPC-254L DC POWER CABLE

Used for charging with an external power supply.

### • UT-80/UT-96 (2-TONE/5-TONE UNIT)

Provides 2-tone or 5-tone capabilities.

## ◇ Battery pack

Battery pack	Voltage/capacity	Charging period with BC-119
BP-196R	9.6V/1050mA	Approx. 2.0 hours

**Count on us!**

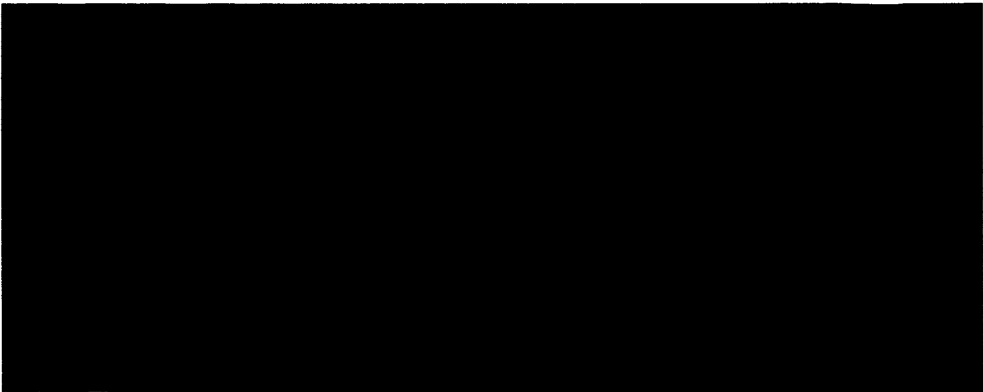

A-5424X-1THA

Copyright © 1996 by Icom Inc.

**Icom Inc.**  
6-9-16 Kamihigashi, Hirano-ku, Osaka 547 Japan

